



# STROBELL®

## COMBINED FIRE ALARM BELL & VISUAL INDICATING DEVICE

Manufactured by Vimpex in the UK, the StroBell® is a combined fire alarm bell and visual indicating device which is ideal for installations that require both a traditional bell tone as well as a visual alarm.

The StroBell® uses the same hinged design as the ClamBell® meaning installers benefit from reduced installation time. Once fitted to the wall and wired to the circuit, the StroBell® clicks shut.

With an ultra bright LED, the StroBell® offers flexibility to the installer by offering different options for brightness and flash frequency.

The StroBell® offers fully customised pad printed branding with your company logo.\*



### Specification

Max Current Consumption	Bell & Normal Output Strobe: 27 mA Bell & High Output Strobe: 47 mA
Operating Voltage	20-28 Vdc (24 Vdc Nominal)
Sound Output	96 dB(A) @ 1m
Temperature Range	-10 to +50°C
IP Rating	IP21C
Material	Aluminium (Gong) ABS (Plastics)
Colour	Red
Mounting Options	Shallow Base
Weight	562 g
Dimensions	213 (H) x 150 (W) x 60 (D)
Flash Rate	0.5Hz/1Hz

# STROBELL®

### Features

- / Ultra bright LED
- / Different options for brightness and flash frequency
- / Same easy installation as ClamBell®
- / Slick and modern looking
- / Fully customised pad printed branding\*
- / StroBell® strobe and bell can operate independently or combined

\*Subject to minimum order quantity

## Part Numbers

StroBell

SBE6-RD-24-EN-RW

StroBell Combined Fire Alarm Bell, Red, 24 V, Shallow Base

## Dimensions (mm)

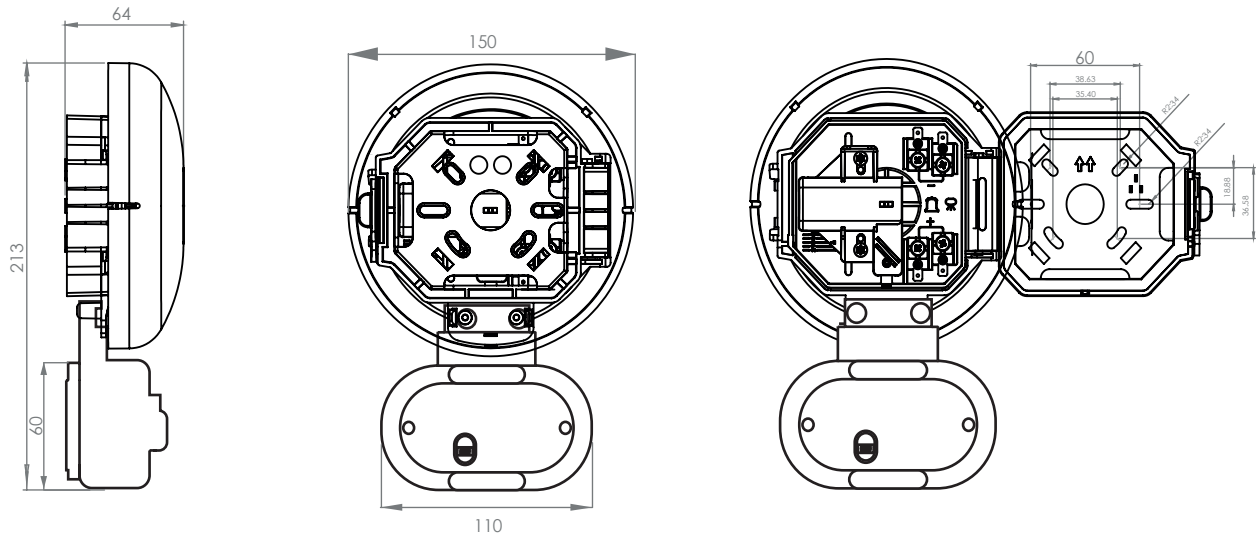

3700125\_REV0500

We reserve the right to change or amend any design or specification in line with our policy of continuing development and improvement.

Vimpex Ltd, Star Lane, Great Wakering, Essex, SS3 0PJ, UK  
Vimpex Europe BV / Vimpex Sweden AB / Vimpex Safety Products Limited

+44 (0) 1702 216 999 / [sales@vimpex.co.uk](mailto:sales@vimpex.co.uk) / [vimpex.co.uk](http://vimpex.co.uk)

Registered in England No.2915112 Registered Address: Star Lane, Great Wakering, Essex, SS30PJ, United Kingdom



Quality System Certificate No. 456  
Assessed to ISO 9001