

Peripheral Relay

MxPro

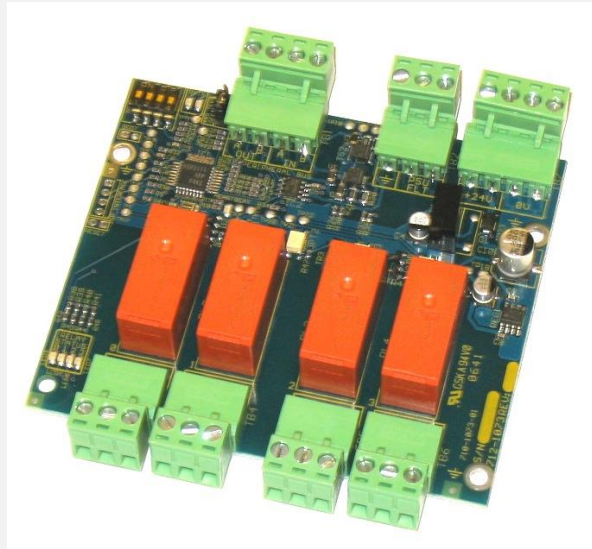

The Programmable 4-Way Relay Card is an optional peripheral unit that provides four individually programmable relay output circuits.

Up to 16 Cards can be connected to a multi-loop panel giving a maximum of up to 64 additional local relay outputs.

Each output is fully programmable using the powerful 'Dynamix' cause and effects rules and all outputs are synchronised.

The unit is available as either a printed circuit card only or as a boxed version with integral 1A power supply.

Features

- Each output is 230V, 5A rated*. Each output is individually programmable with any of the available 'Dynamix' cause and effects rules.
- Up to 16 cards can be connected giving a total of 64 additional outputs.
- Each output may be individually programmed for silence, walk test and investigation delay.
- An Input is provided to monitor the fault output from a power supply.

The operation and functions described in this manual are available from Software Version 021-03 onwards.

Specifications:

Models, Sales Order Parts:

Mxp-035 : 4-Way Programmable Relay Card
Mxp-035-BXP : 4-Way Programmable Relay Card Boxed with 1A PSU

Applications / Limitations:

Plant Control and Signalling relay outputs.

Each output can be assigned to an individual output group and is fully programmable for any output function allowed within the configuration program.

Only one 4 Way Relay Output Card can be fitted within an control panel.

Fitting of the Mxp-035 in an MxPro 4 panel precludes fitting of other panel input or output cards. See panel manuals for further information.

Compatibility:

Can be used with MxPro 4, MxPro 5 and Axis EN Panels.

4200, 4400 and 4800 control panels programmed with Version 021-03 software (or later) and fitted with base card hardware revision levels 10 (712-1022 Mx-4400) and 09 (712-1022-002 Mx-4200) or later.

Compatible with the PC Configuration Tool from version 4.7 or later.

Requires installation of the Mxp-031 Peripheral Bus Interface Adaptor card in the panel.

Item	Specification Details
Applicable Standards	EN54-2: 1997, BS EN54-4: 1997
Operating Temperature	-5°C to 40°C
Relative Humidity	95% non-condensing (maximum)
Enclosure	Steel, IP30, RAL9002, 320 mm high x 345 mm wide x 88 mm deep, 3kg (excluding batteries)
Knockouts 20mm	7x Top, 2x Bottom
AC Supply	230V AC, 50Hz (+10%, -15%) FUSE T3.15H250
Standby Battery	2x12V, 7AH Sealed Lead-Acid Type (Yuasa recommended)
LED Indications (Box)	Power and General PSU Fault – Separate indications of specific PSU fault conditions are available on the PSU.
PCB	110 mm x 86 mm x 18 mm, 130 grams
PCB Supply	24VDC nominal (18-28VDC), (quiescent) 22mA (all outputs on) 75mA typical, 100mA maximum
LED Indications (PCB)	Relay Circuit ON, Communications TX & RX and Heartbeat
Outputs (x4)	230V AC, 5A resistive / 230V AC, ½ HP / 30VDC, 5A 30VDC, 1A when mounted on panel chassis Minimum 20mA wetting current
EOLR (Fault Input)	10kΩ
EOLR (Peripheral Bus)	150Ω (applied via “485 term” jumper – see section 2.6.3)

As our policy is one of constant product improvement the right is therefore reserved to modify product specifications without prior notice

Table of Contents

Page

1	INTRODUCTION.....	4
2	INSTALLATION.....	5
2.1	ENCLOSURE.....	5
2.2	PCB MOUNTING IN SEPARATE ENCLOSURE	5
2.3	PCB MOUNTING IN A 4200 / 4400 PANEL.....	6
2.4	PCB MOUNTING IN A 5000 PANEL	6
2.5	DIP SWITCH CONFIGURATION	6
2.6	WIRING	7
2.6.1	AC Wiring (Boxed Units)	7
2.6.2	Battery Installation (Boxed Unit)	7
2.6.3	DC Power and Serial Communications	8
2.6.4	Power Supply Fault Input.....	8
3	PROGRAMMING AND CONFIGURATION	9
3.1	ADDING DEVICES.....	9
3.2	REMOVING DEVICES	10
3.3	CONFIGURING THE OUTPUT CIRCUITS.....	10
3.3.1	Basic Details	10
3.3.2	Detailed Configuration	11
3.3.3	Output Group Cause and Effect Assignment.....	11
3.4	OUTPUT GROUP PROGRAMMING	11
3.4.1	Basic Options	11

1 Introduction

Four relay outputs are provided. These can be independently programmed with different cause and effect rules.

The outputs can be configured to turn ON only.

The PC CONFIG tool is used to program the presence and functionality of these outputs. By default, the outputs cannot be silenced. The outputs can be configured to follow investigation delays, allow silence and be inverted, if required.

When “All Other Outputs” are disabled at the panel, all relay outputs attached to the panel are disabled. Outputs can also be individually disabled via the user menus or disabled using the group disable function through programming.

The Boxed unit is provided with a power supply. Status indications for Power and Fault are provided.

On-board indicators are provided for each relay output (illuminated when the relay is activated), Bus communications Transmit TX and Receive RX and a Heartbeat indicator (flashes at a rate of 1Hz to show normal operation and at a rate of 5Hz to show an internal fault condition).

2 Installation

2.1 Enclosure

The enclosure dimensions, fixing points and general arrangement are shown in FIGURE 1 opposite:

Space is provided in the bottom of the enclosure for 2x 7AH batteries.

Enclosure cover is fixed to the back box with 2x hex M4 screws.

Ensure that the earth lead from the cover is securely connected to the earth tab in back box before refitting.

Cover is 345 (w) x 320 (h).

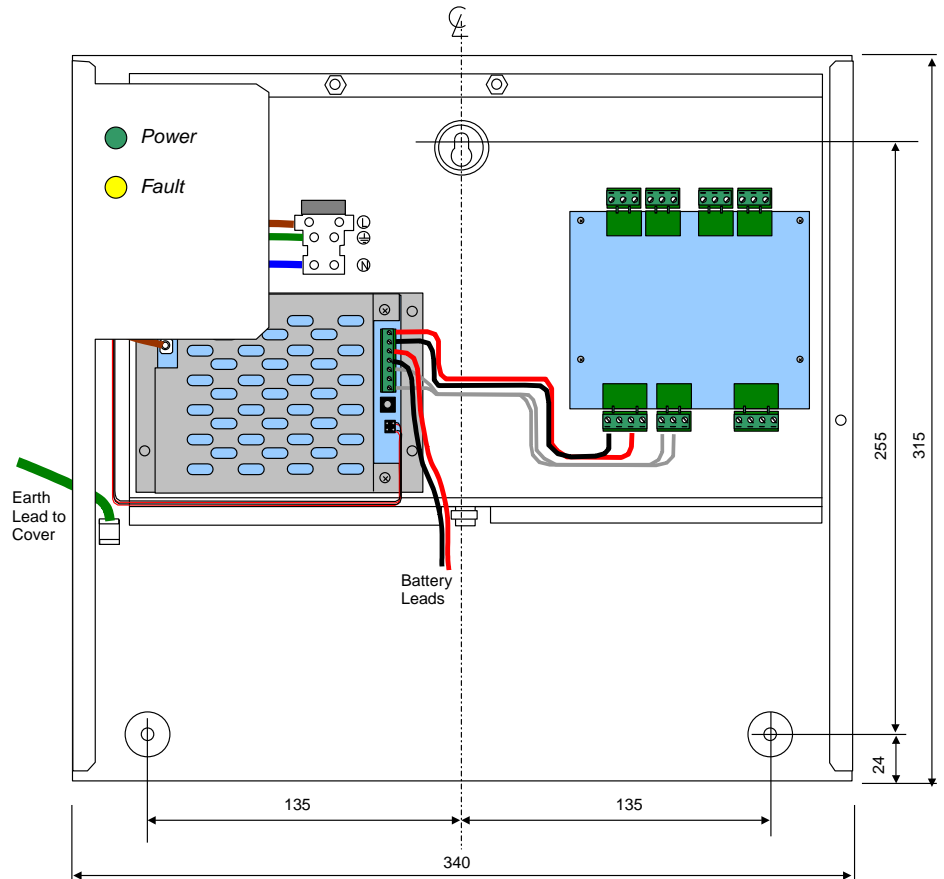



FIGURE 1

2.2 PCB Mounting in Separate Enclosure

The printed circuit card shall be fitted to a metal chassis or in a metal enclosure using the M3 spacers, nuts and screws supplied.

The chassis / enclosure must be  connected to protective earth.

Refer to the diagram opposite for dimensions and fixing positions.

Fixing positions marked * must be securely fixed to provide an earth connection for EMC purposes. Brass spacers are provided for this purpose.

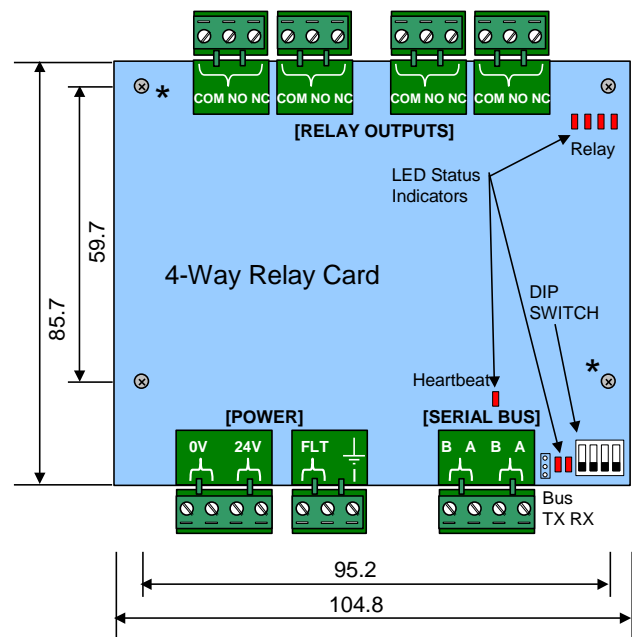

FIGURE 2

2.3 PCB Mounting in a 4200 / 4400 Panel

The card may be fitted to the chassis using 4x M3 screws. Refer to Figure 3 opposite.

Screws marked * must be securely fixed to provide an earth connection for EMC purposes.

Where the unit is used for lightly loaded outputs, the power may be supplied by the AUX 24VDC panel supply output.

In this case, check and ensure that the power supply and battery standby can support the application.

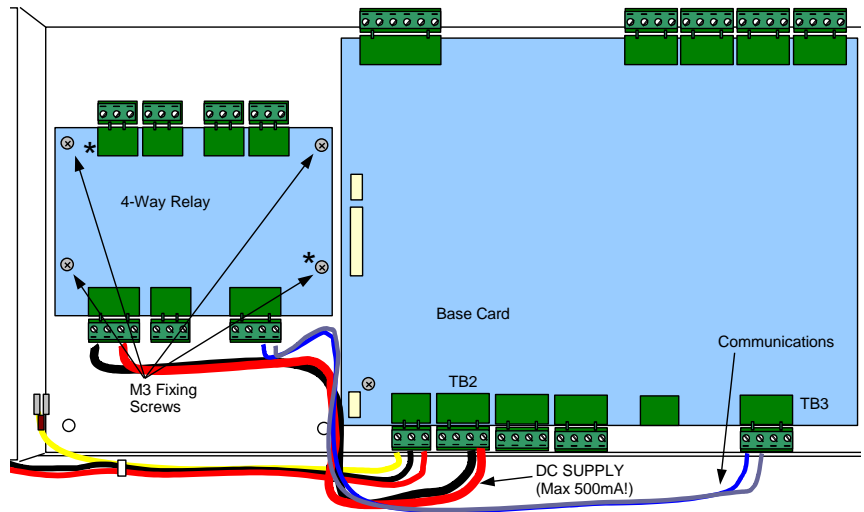

FIGURE 3

Wiring should be in accordance with subsequent sections of this manual.

Refer to FIGURE 3 above for the recommended routing of cables.

2.4 PCB Mounting in a 5000 Panel

There is provision on the 5000 chassis plate to mount one peripheral bus module (except 5100 small enclosure). Refer to panel manual 680-165 for further information.

2.5 DIP Switch Configuration

Each 4-Way Relay Card must be given a unique address.

The interfaces are added to the configuration file in the PC CONFIG tool at Peripheral Bus Address 66-81.

The DIP Switch on each unit must be set accordingly to the corresponding address defined. See table opposite.

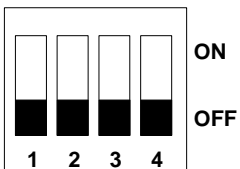

Address	SW1-1	SW1-2	SW1-3	SW1-4
66	OFF	OFF	OFF	OFF
67	ON	OFF	OFF	OFF
68	OFF	ON	OFF	OFF
69	ON	ON	OFF	OFF
70	OFF	OFF	ON	OFF
71	ON	OFF	ON	OFF
72	OFF	ON	ON	OFF
73	ON	ON	ON	OFF
74	OFF	OFF	OFF	ON
75	ON	OFF	OFF	ON
76	OFF	ON	OFF	ON
77	ON	ON	OFF	ON
78	OFF	OFF	ON	ON
79	ON	OFF	ON	ON
80	OFF	ON	ON	ON
81	ON	ON	ON	ON

2.6 Wiring

The unit is designed for easy wiring installation.

“Plug-in” terminal blocks are provided for all connections to the unit.

FIGURE 2 above shows the positions for all connections to the card.

NB: Minimum / Maximum cable size for terminal block connections is limited to 0.35mm² - 2.5mm² (22-14AWG).

NB: Maximum rating of relay contacts when mounted in the fire panel is 24V, 1A – DO NOT USE for 230V AC switching.

WARNING: If the card is used to switch 230V AC then the cables should be of suitable size and insulation for the voltage / current load. Keep this wiring away from any SELV wiring. Fit warning label next to connections.

230V AC MUST BE the same phase in the enclosure!

If the loads are inductive then ensure there is protection against back EMF. Use the appropriate snubber network.

All electrical wiring installation work should be carried out in accordance with the code of practice applicable in the country of installation. To maintain electrical integrity of the SELV wiring on the DC Power and communications lines all SELV wiring should be segregated from LV mains wiring and be wired using cable with insulation suitable for the application.

To minimise the effects of EMC interference all data wiring circuits should be wired with a twisted pair of conductors with a cross sectional area suitable for the loading conditions.

In areas where cabling may come into contact with high frequency interference, such as portable radio transceivers etc. the data wiring cable should be of a twisted pair construction within an overall screen. Care should be taken to correctly terminate this screen, refer to the information below.

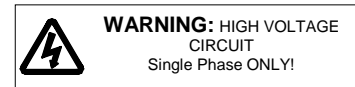

2.6.1 AC Wiring (Boxed Units)

Route the high voltage mains AC wiring into the enclosure at the upper left corner only. Keep the AC wiring away from the circuit boards and all other wiring.



The panels must be connected to the supply earth through the power cable.

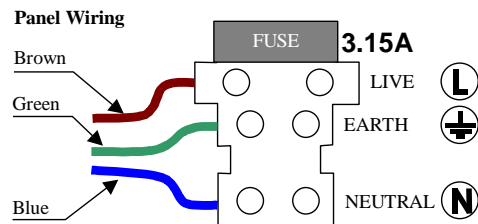

FIGURE 4

The mains input connector is shown in the diagram opposite. Note the positions of the earth, neutral and live terminal connections. These are clearly marked on the label next to the connector. The connector block contains an integral fuse holder.

Secure the mains input wiring by tie wrap as close to the terminal block as possible.

The fuses are rated at: T 3.15A H 250V

Replace with correct rating and specification only.

Connect the Unit to the mains supply via a readily accessible disconnect-device (Isolation Switch) and suitable earth fault protection incorporated in the building installation wiring. The Mains cable should be 0.75mm² cable rated at 250V and fused via a 5A anti-surge fuse.

2.6.2 Battery Installation (Boxed Unit)

Two 7AH batteries can be installed in the bottom of the enclosure.

Battery Leads are supplied.

Connect as shown in FIGURE 5 opposite.

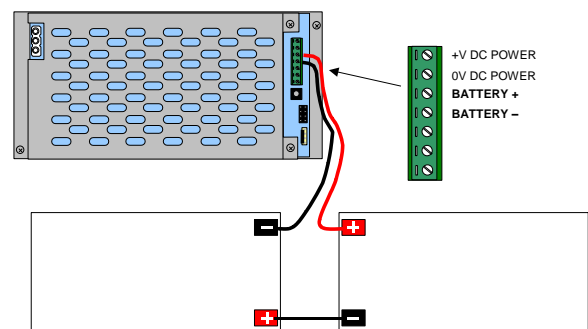

FIGURE 5

OBSERVE POLARITY OF CONNECTIONS

2.6.3 DC Power and Serial Communications

A 24V DC power supply is required.

Connect the 24V DC supply feed input to the SUPPLY +24V and 0V terminals on the interface card.

Use cables of sufficient size to ensure that the power input voltage is maintained under all supply conditions – refer to specifications section.

Note: The DC power supply used **MUST BE** designated a Safety Extra Low Voltage (SELV) supply.

For boxed versions, supplied complete with a power supply, DC Power is pre-wired. Refer to details above for the AC Power connections.



The enclosure in which the card is mounted must be earthed and the card fixing points defined in FIGURE 2 must be connected to earth for EMC purposes.

OBSERVE POLARITY OF CONNECTIONS

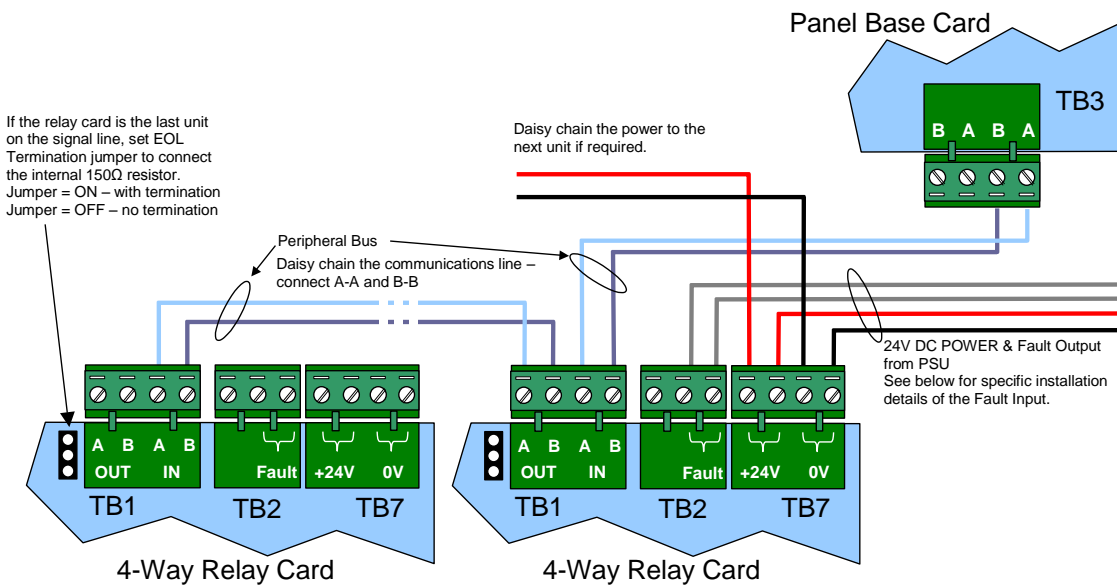

FIGURE 6

!
Critical Signal Path

The serial communications is a 2-wire bus. Communications cable must be twisted-pair type. See FIGURE 6 above for connections. Set the position of jumper 485 TERM to 'ON' to connect a 150Ω EOL resistor on the last unit on the bus. Otherwise, leave this jumper in the 'OFF' position.

The interfaces and enclosures should be located not greater than 10M from the control panel (and must be within the same room) with the wiring run in rigid metal conduit or using fire rated cables.

2.6.4 Power Supply Fault Input

The "FAULT INPUT" terminals are normally used to monitor the contacts of the fault relay output from the power supply.

A 10KΩ series resistor should be connected to the relay terminals.

If more than one module is powered from the same power supply, it is only necessary to connect the fault output monitoring to one of the modules.

Should no fault relay be available, or if the monitoring of an external fault signal is not required, these two terminals should be shorted together with a 10KΩ resistor across the terminals of the "FLT-INPUT" terminal block.

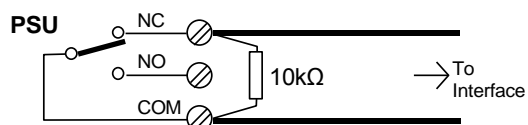

FIGURE 7

3 Programming and Configuration

To add a 4-way relay card in the configuration file firstly expand the panel tree and select the “Peripheral Bus” option.

Note: The peripheral addresses are assigned in blocks. Addresses 50-65 are assigned to the 4-Way Sounder and addresses 66-81 are assigned to the 4-Way Relay.

3.1 Adding Devices

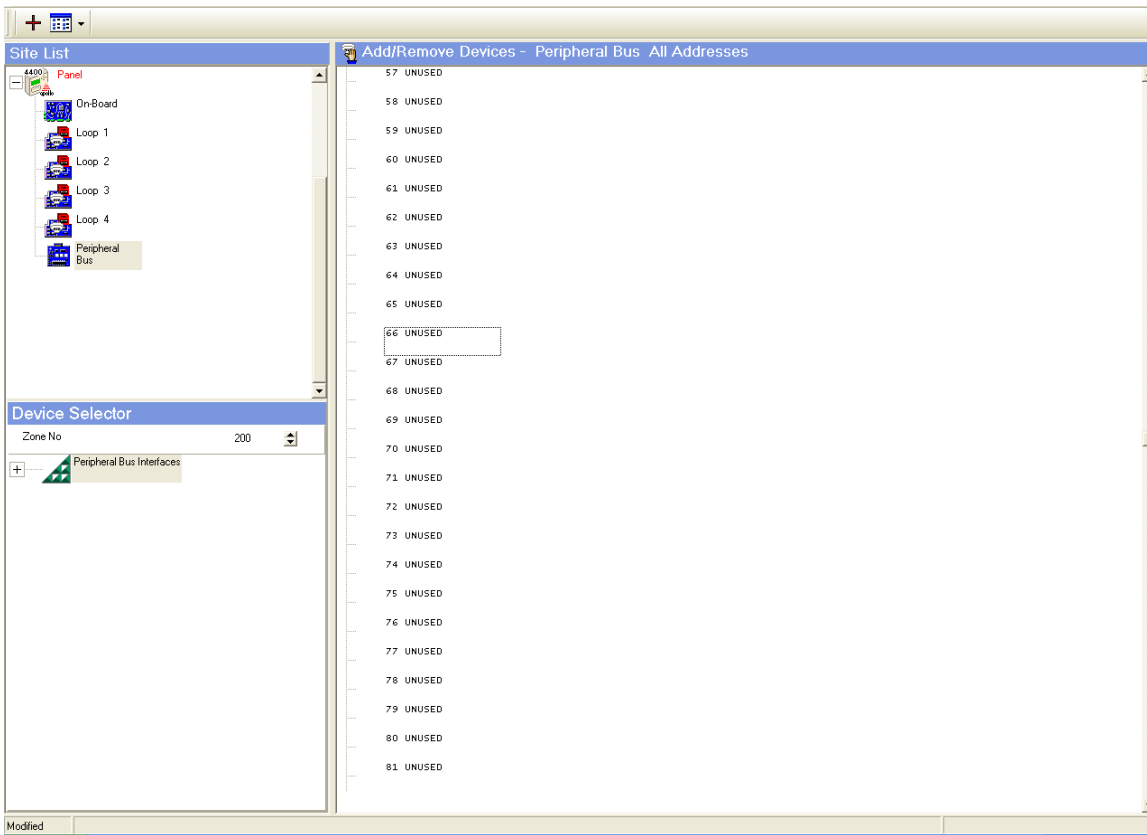

Click  on the device selector and expand the tree and click on the Mxp-035 option to highlight and select it.

The zone number is pre-assigned to the zone number of the panel. This can be changed if an alternative zone is required for these circuits.

Select the required address in the list and then click  on the tool bar to add the device at the selected address (or right click and select add).

Continue and add 4-way relay cards at additional addresses if required.

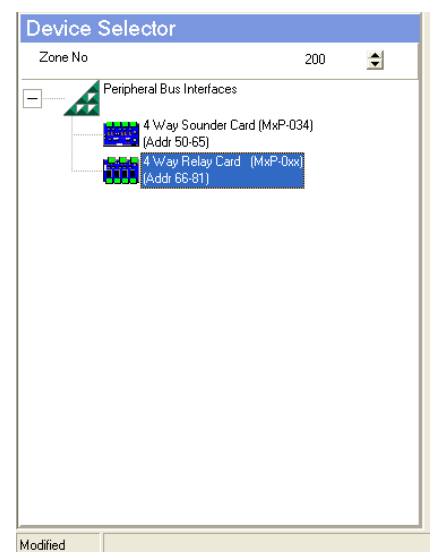

Remember that the DIP Switch on the card(s) will need to be set to match the addresses chosen in the configuration file.

An example of a panel with five (5) relay cards is shown below.

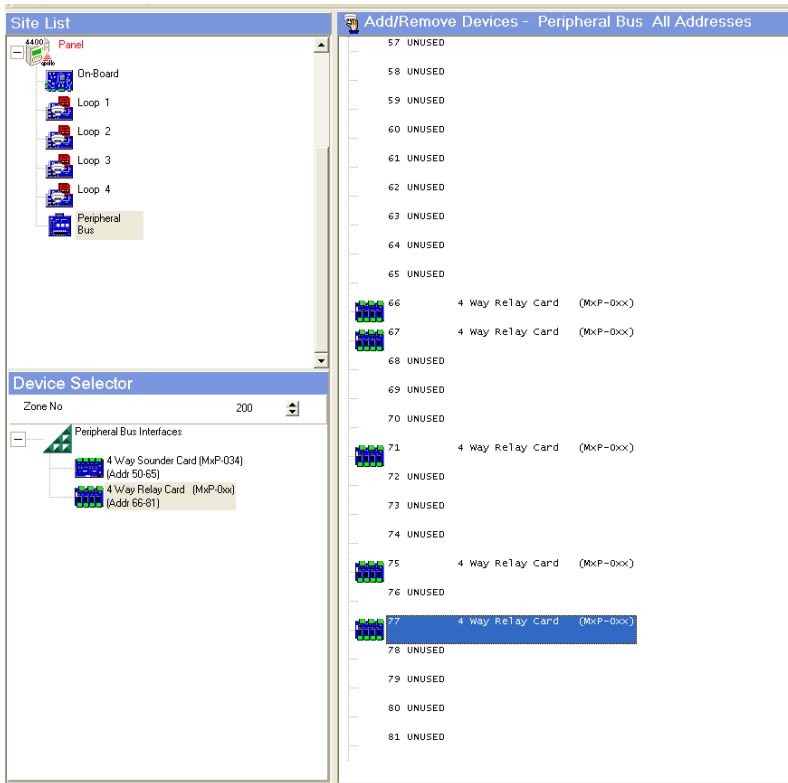



3.2 Removing Devices

To remove a device, click on the  button, select and highlight the address to be removed and then click the  button to delete the 4-way relay card from the address.

3.3 Configuring the Output Circuits

3.3.1 Basic Details

Click the  button to show a list of the addresses and sub-addresses for all of the devices added. An example is shown below:

Each output is a sub-address of the main card address. For example, at address 66, Relay 0 = 66.0, Relay 1 = 66.1, etc.

Device Information - I/O Interface All Points					
Address	Type	Device Location Text	Zone	Group	
66.0	Relay		Zone 200	O/P Group 199	
66.1	Relay		Zone 200	O/P Group 199	
66.2	Relay		Zone 200	O/P Group 199	
66.3	Relay		Zone 200	O/P Group 199	
67.0	Relay		Zone 200	O/P Group 199	
67.1	Relay		Zone 200	O/P Group 199	
67.2	Relay		Zone 200	O/P Group 199	
67.3	Relay		Zone 200	O/P Group 199	
71.0	Relay		Zone 200	O/P Group 199	
71.1	Relay		Zone 200	O/P Group 199	
71.2	Relay		Zone 200	O/P Group 199	
71.3	Relay		Zone 200	O/P Group 199	
75.0	Relay		Zone 200	O/P Group 199	
75.1	Relay		Zone 200	O/P Group 199	
75.2	Relay		Zone 200	O/P Group 199	
75.3	Relay		Zone 200	O/P Group 199	
77.0	Relay		Zone 200	O/P Group 199	
77.1	Relay		Zone 200	O/P Group 199	
77.2	Relay		Zone 200	O/P Group 199	
77.3	Relay		Zone 200	O/P Group 199	

3.3.2 Detailed Configuration

Detailed output configuration is shown in the 'Point window for the selected address. For example:

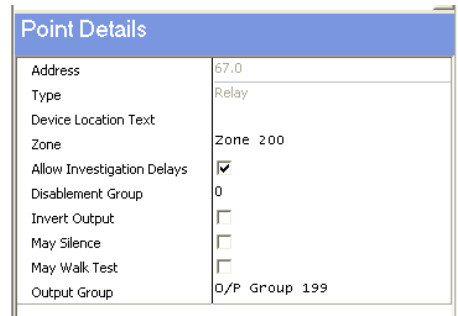

Details'

Option	Description	Default
Device Location Text	Enter the Device Location text to describe each relay circuit. If required, the Zone Number can also be changed.	
Zone	This is normally the panel zone but can be changed on an individual point if required.	
Allow Investigation Delays	Determines if the output will follow any programmed investigation delays or will activate immediately on the event.	Yes
Disablement Group	The output can be assigned to a disablement group. When the group is disabled, the output will not activate on an event. 0 = not assigned to a disablement group.	0
Invert Output	Determines if the output is normally OFF (not inverted and activates on the event) or normally ON (inverted and de-activates on the event)	No
May Silence	Determines if the output will be silenced when a Silence command is performed.	No
May Walk Test	Determines if the output will respond to "Test" fire alarms.	No
Output Group	Determines the cause and effects rule that will turn the output on.	199

3.3.3 Output Group Cause and Effect Assignment

By default, all outputs are pre-assigned to the default general fire alarm output group (199).

Assign the output to an alternative output group depending on the cause and effects required for each output.

3.4 Output Group Programming

3.4.1 Basic Options

Each output can be independently programmed in the same way as other outputs on the panel including delays, zone range, input events and logic.

For further information, refer to the panel manuals and PC Tool manual.

Doc Number: 680-133

Revision: 02A



Advanced Electronics Ltd
Moorland Way, Cramlington, Northumberland, NE23 1WE UK

Tel: +44 (0)1670 707 111

Fax: +44 (0)1670 707 222

Email: sales@advancedco.com

Web: www.advancedco.com